

INSTRUCTION SHEET

RAS - TB - Cable Tie Back Option

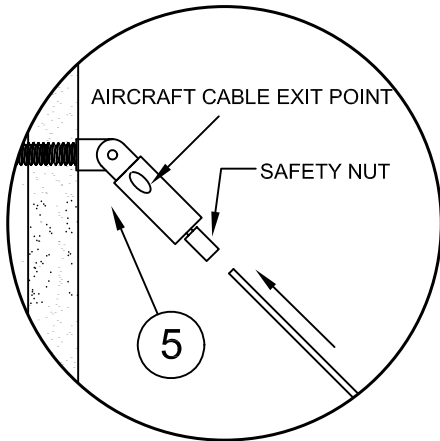

1. During fixture installation, attach arm ring to desired position. Should be set to at the middle of arm to be most effective.
2. Attach 1/4-20 threaded set screw to secure arm ring to arm and thread on cable gripper to set screw.
3. Cut off die-cast end stop on aircraft cable, being careful not to fray ends. Feed aircraft cable into gripper, attach to arm ring.
4. Attach cable gripper to 1/4-10 stud (by others) at wall to same distance that ring is set at, to create a 45 degree angle.
5. Feed aircraft cable through the safety nut to desired length. (cut extra cable if necessary)

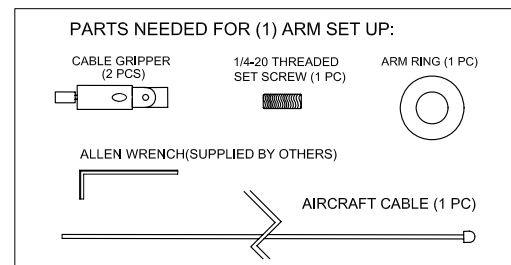
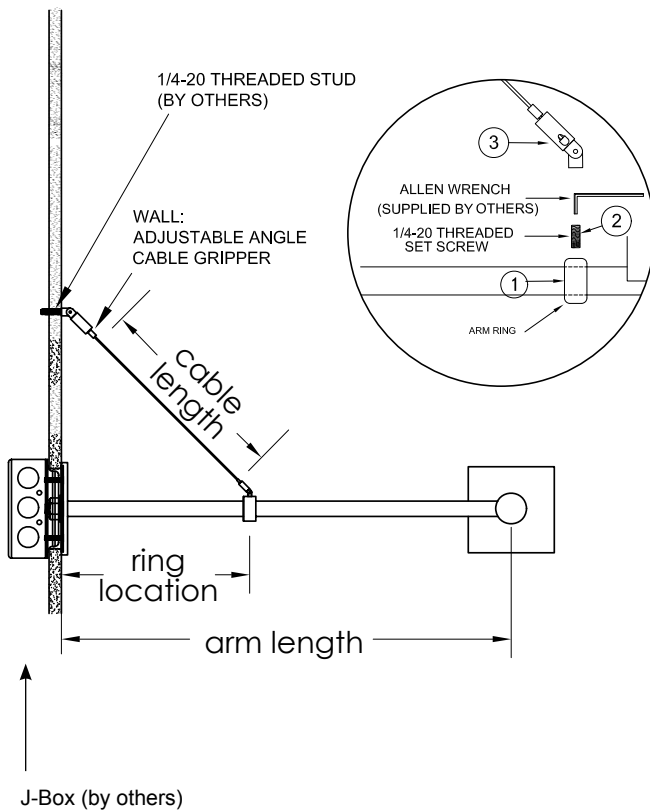

Note: To be installed by a qualified electrician per N.E.C. and all local codes.

820-00043

V-0714