

INSTRUCTION SHEET

NCP - RAS Installation Guide

NO COVER PLATE TRIM RING OPTION

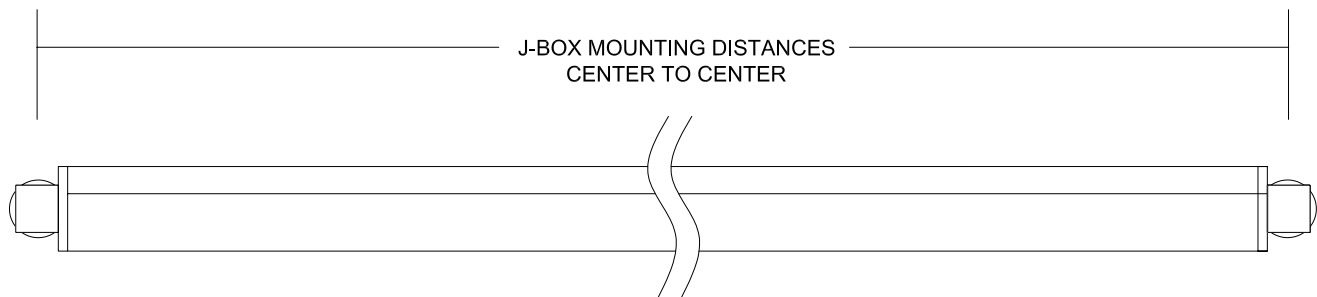
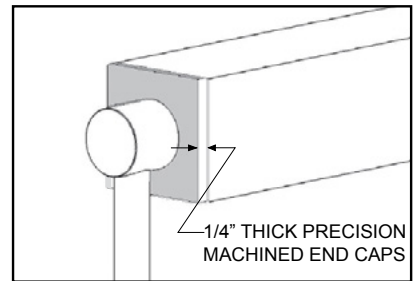
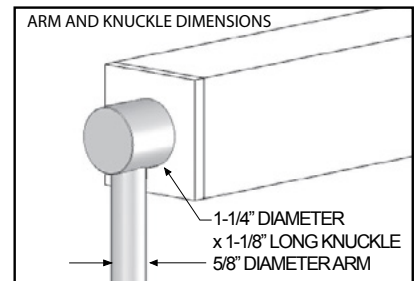
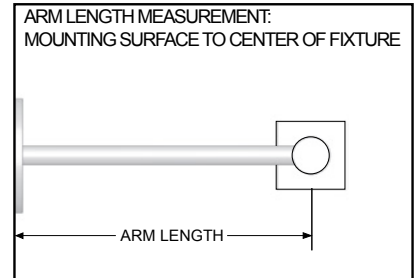
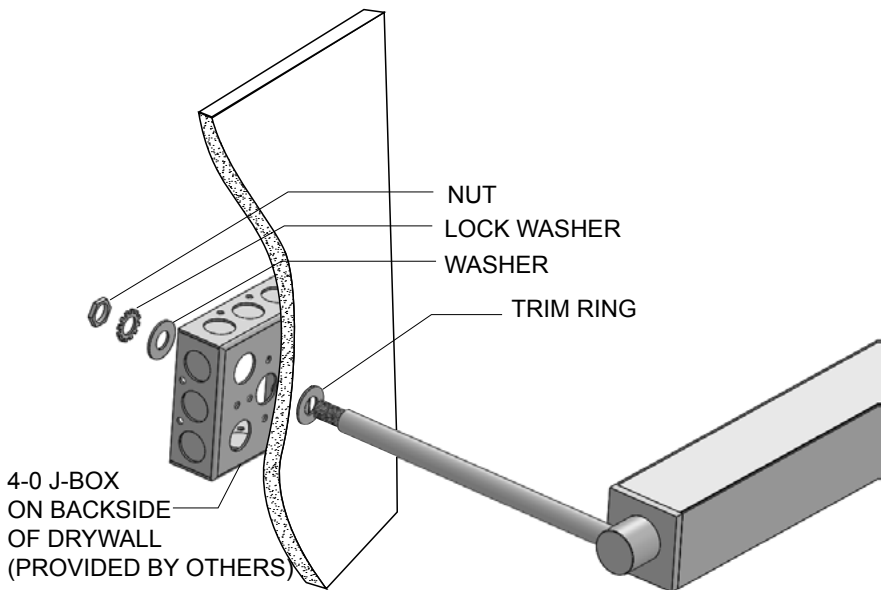

See continuous run matrix pages for fixture length and cable spacing

Note: To be installed by a qualified electrician per N.E.C. and all local codes.

INSTRUCTION SHEET

RAS-NMP/ TR1 Trim Ring Options

NMP - No Trim Option

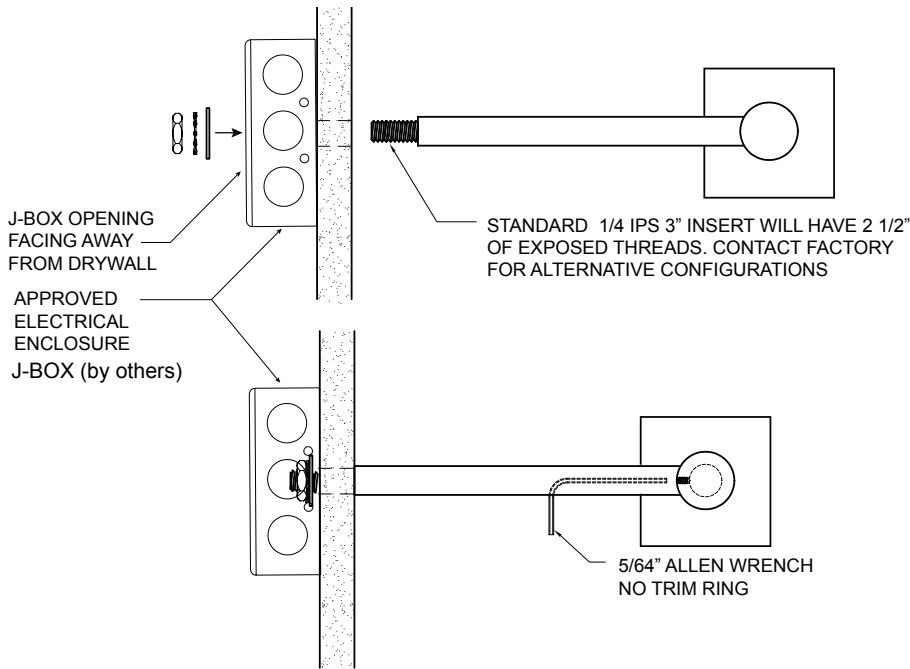

TR1 - 1" Trim Ring Option

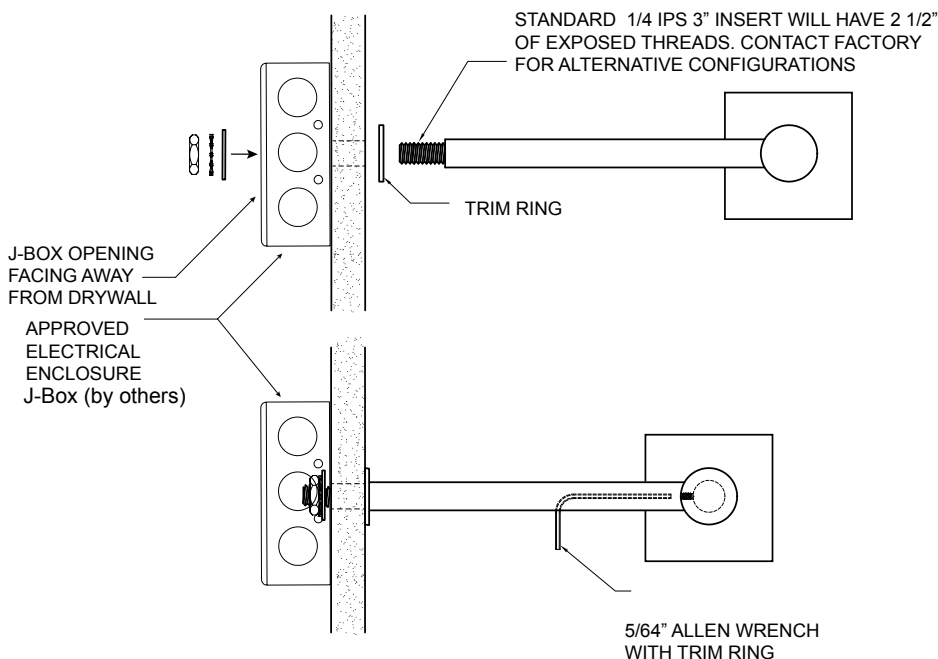

1. Align fixture arms and tighten set screws (insure rotation is possible, arms can be adjusted to where the fixture cannot rotate).
2. Drill 33/64" or 17/32" holes in mounting surface. Reference "Fixture Spacing" worksheet for spacing information.
3. Approved electrical enclosure must be installed on the back side of the mounting surface.
4. If using trim ring, slide one over each threaded nipple.
5. Install fixture - insert adjustable threaded ends through drilled holes.
6. Slide on flat washer and star washer.
7. Securely tighten with nuts on each arm
8. Run wires via supplied coupler and 3/8" flexible conduit fittings to J-Box (by others) or power supply housing and complete wire make-up per supplied wiring diagram.
9. Use 5/64" Allen wrench to loosen fixture at arm knuckles.
10. Adjust fixture as desired and tighten set screws to secure in place. Set screw may be left loose for adjustment if desired.

Note: To be installed by a qualified electrician per N.E.C. and all local codes.

820-00042

V-0714

INSTRUCTION SHEET

RAS - TB - Cable Tie Back Option

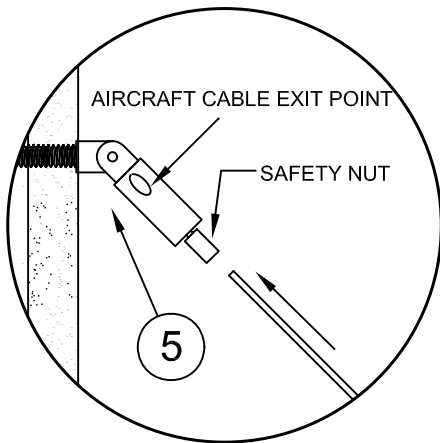

1. During fixture installation, attach arm ring to desired position. Should be set to at the middle of arm to be most effective.
2. Attach 1/4-20 threaded set screw to secure arm ring to arm and thread on cable gripper to set screw.
3. Cut off die-cast end stop on aircraft cable, being careful not to fray ends. Feed aircraft cable into gripper, attach to arm ring.
4. Attach cable gripper to 1/4-10 stud (by others) at wall to same distance that ring is set at, to create a 45 degree angle.
5. Feed aircraft cable through the safety nut to desired length. (cut extra cable if necessary)

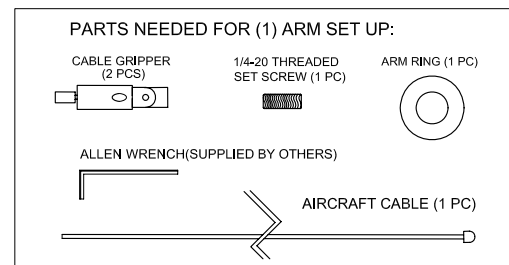
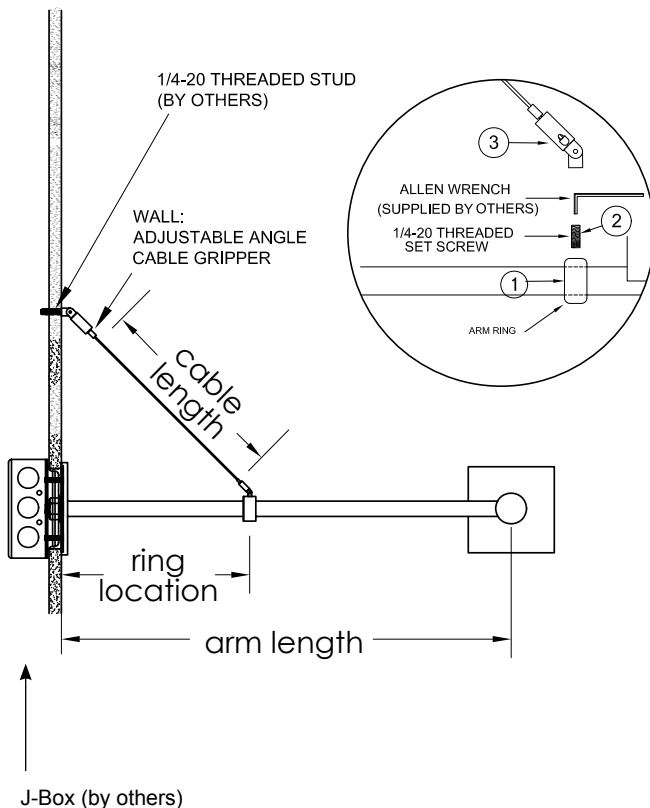

Note: To be installed by a qualified electrician per N.E.C. and all local codes.

820-00043

V-0714

INSTRUCTION SHEET

Connection & Wiring

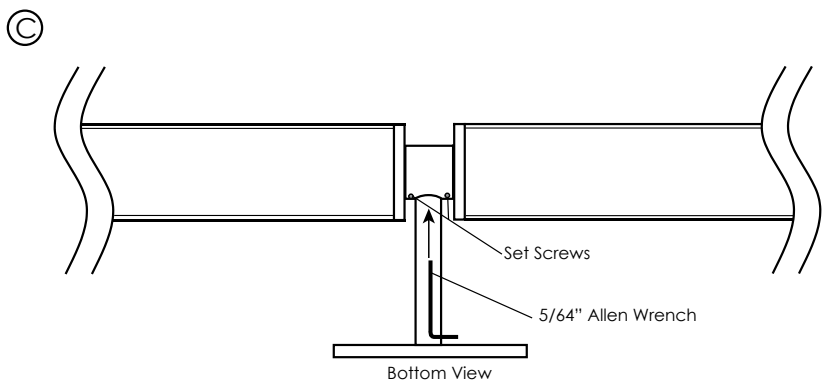
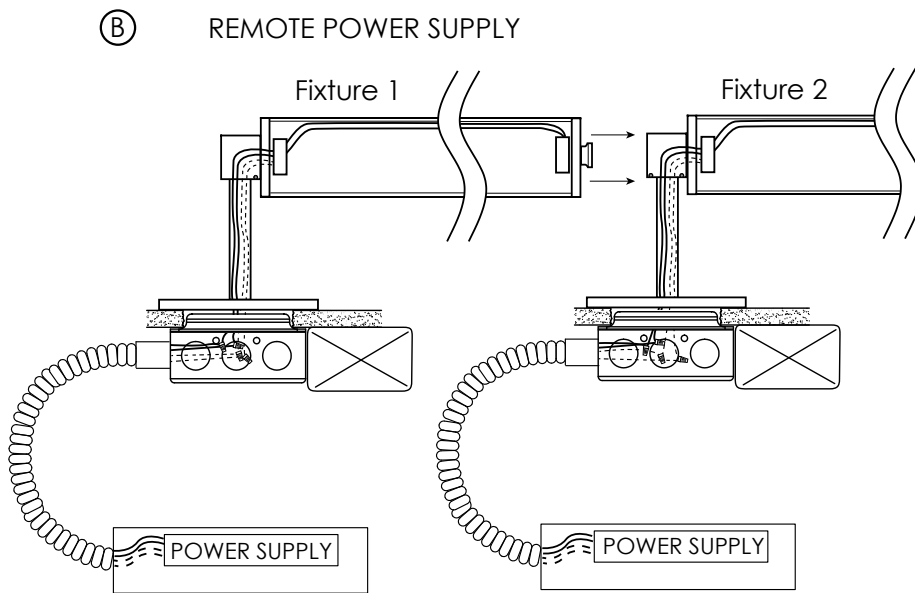
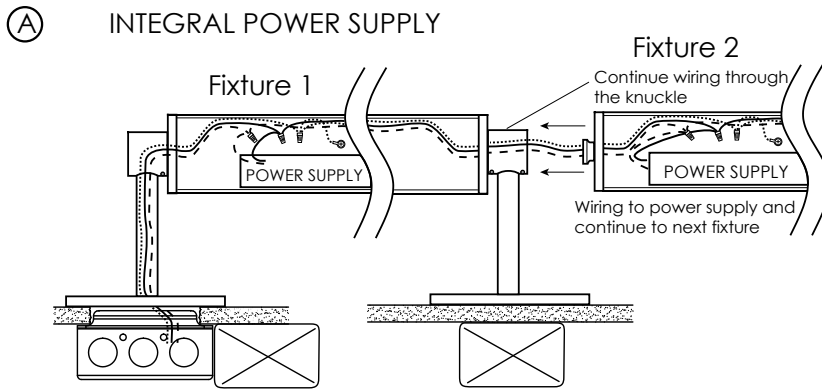

1. Install J-box (by others) with Mud Ring (provided by contractor).
2. Slide cover plates over arms, slide threads through mounting plate, star washer and flat washer, securely tighten with nut - make sure mounting holes align with mud ring holes.
3. Complete wire make-up per code to J-Box or power supply housing and complete wire make-up per supplied wiring diagram.
4. Securely mount fixture to wall with provided 8-32 flat undercut head screws (*Hex head screws provided for short arm applications, Allen wrench not provided*).
5. Slide cover plate over mounting plate (magnets with pull cover plate tight against wall).
6. For integral power supply fixtures, through wire out of 1st fixture, through the knuckle into the second fixture and connect the power to the power supply. (A)
7. For remote power supply fixtures, feed wiring from power supply box into J-box. Bring wiring from fixture, through the knuckle and arm to the J-box to complete wire make up. (B)
8. Connect 2nd fixture into knuckle, tighten set screw to lock into place.(C)
9. To rotate and aim fixture into desired position, use allen wrench to loosen fixture at arm knuckles (C) Lock fixture into place tighten set-screw. Set screw may be left loose for adjustment if desired.

Note: To be installed by a qualified electrician per N.E.C. and all local codes.

All RAS
V-0714